



Carport Torino











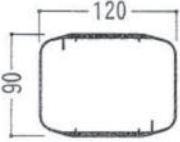
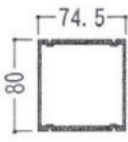
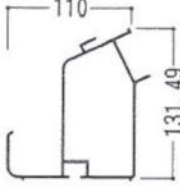
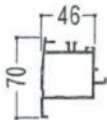
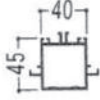



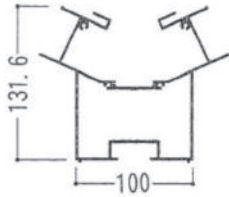

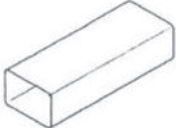
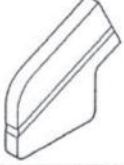
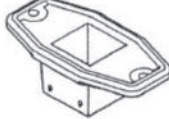





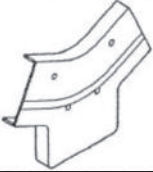

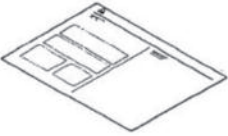
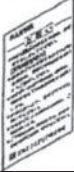



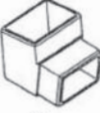

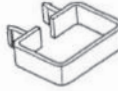



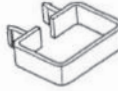

Montagehandleiding

Uitgave : oktober 2009



Dé Carport!

Onderdelen

1 	2 	3 	4 	
5 	6 	7 	8 	
9 	10 			
11 	12 	13 	14 	
15 	16 	17 	18 	
19 	20 	21 	22 	23 
24 	25 	26 	27 	28 
29  (1)	30  (1)	31  (1)	32  (1)	33  (1)
34  (3)	35  (3)	36  (1)	37  (1)	38  (1)
39  (5)	40  (4)	41  (8)	42  (12)	43  (8)
44  (80)	45  (60)	46  (8)		

- 1 *staander*
- 2 *verstevigingsprofiel staander tpv de grond*
- 3 *standaard gootprofiel*
- 4 *eind dakligger*
- 5 *dakligger*
- 6 *glas klemlat*
- 7 *nokprofiel*
- 8 *dwarsligger*
- 9 *lengtekoppelstuk*
- 10 *gootprofiel bij zijdelings gekoppeld*
- 11 *beglazing*
- 12 *afvoerpijp hwa*
- 13 *goot eindkap (kunststof)*
- 14 *koppelstuk staander - goot*
- 15 *kit*
- 16 *funderings ankerstaaf*
- 17 *montagestrip tbv (14) bij standaard montage*
- 18 *montagestrip tbv (14) bij zijdelings gekoppeld*
- 19 *goot koppelstuk (kunststof)*
- 20 *eindstuk goot van (10) bij zijdelings gekoppeld*
- 21 *koppelstuk*
- 22 *montagehandleiding*
- 23 *gebruikershandleiding*
- 24 *rubber tbv gootaansluiting*
- 25 *goot aansluitprofiel*
- 26 *hoekstuk goot*
- 27 *hoekstuk goot*
- 28 *draaibaar hoekstuk*
- 29 *hwa bevestigingsbeugel*
- 30 *hwa beugelsteun*
- 31 *verloopstuk (rond naar vierkant)*
- 32 *PVC-lijm*
- 33 *RVS zelftapper $\varnothing 4 \times 13$*
- 34 *M8x105*
- 35 *dopmoer M8*
- 36 *ring M8*
- 37 *veerring M8*
- 38 *RVS zelftapper $\varnothing 4 \times 10$*
- 39 *RVS zelftapper $\varnothing 4 \times 12$*
- 40 *RVS zelftapper $\varnothing 4 \times 20$*

Maatvoering en funderingsplan standaard uitvoering

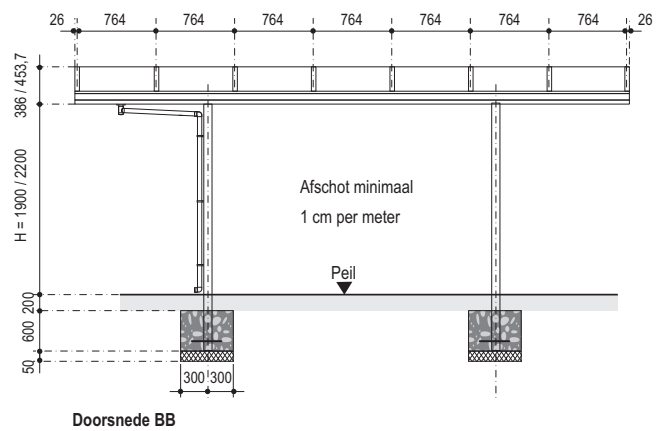
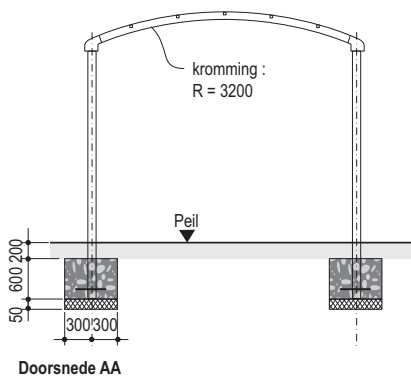
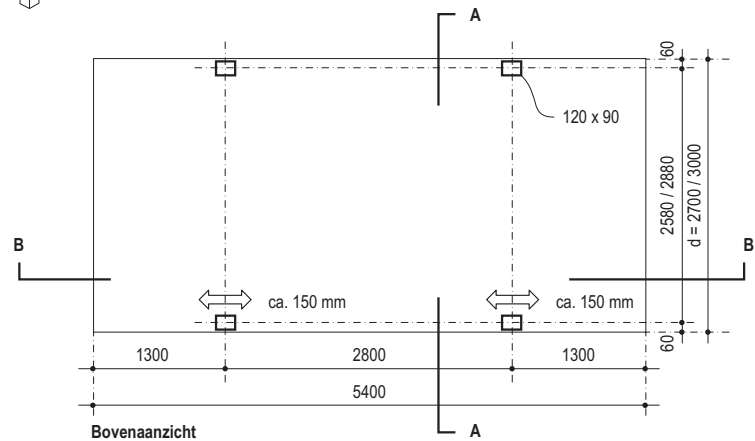
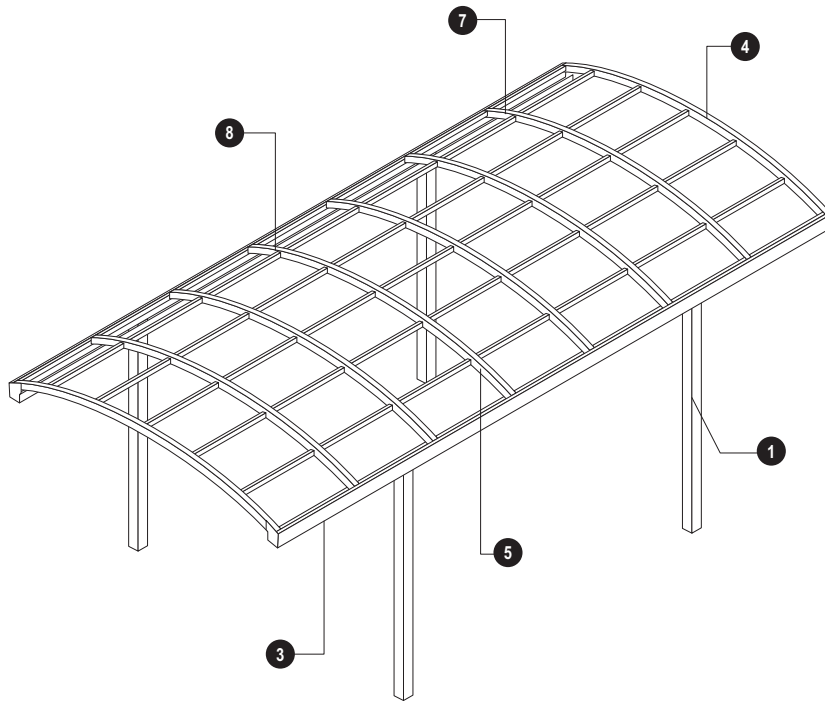

Maatvoering zijdelings gekoppeld

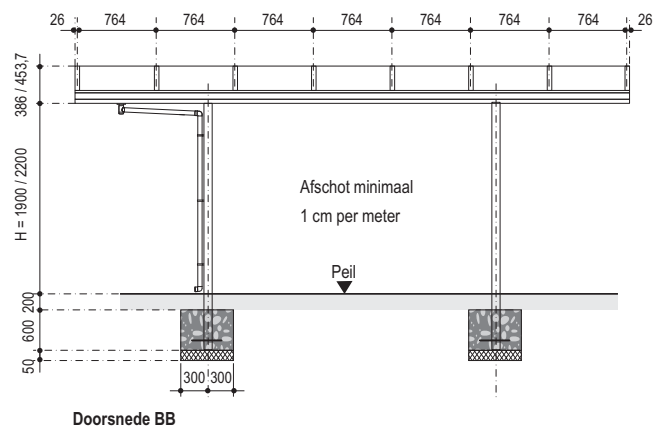
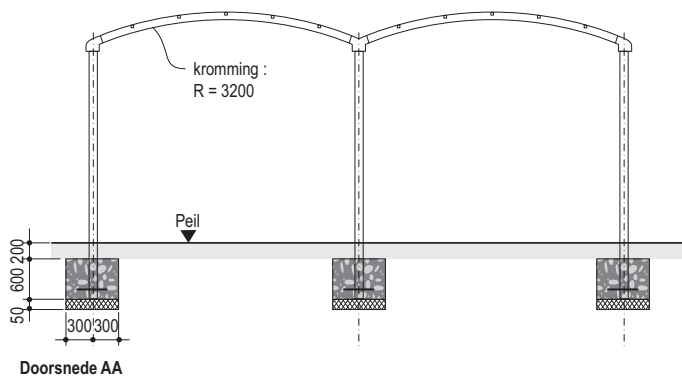
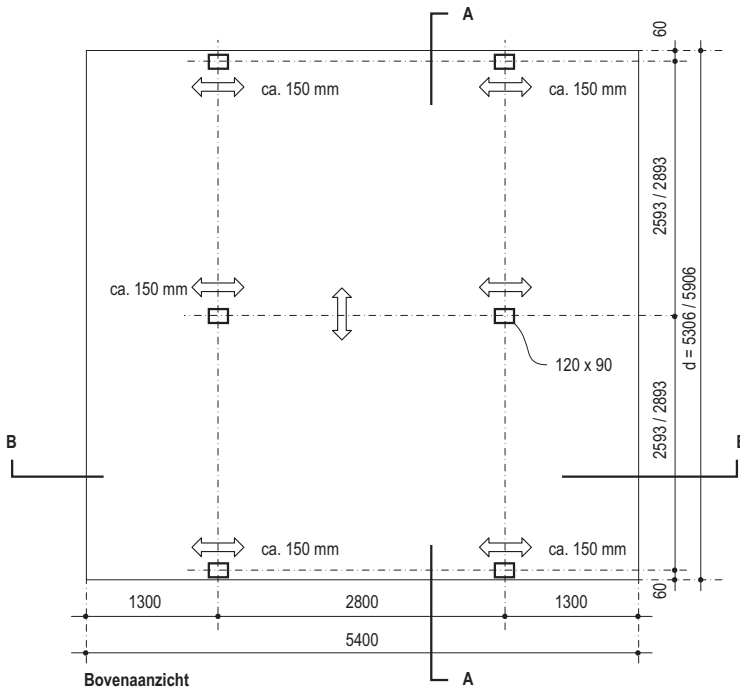
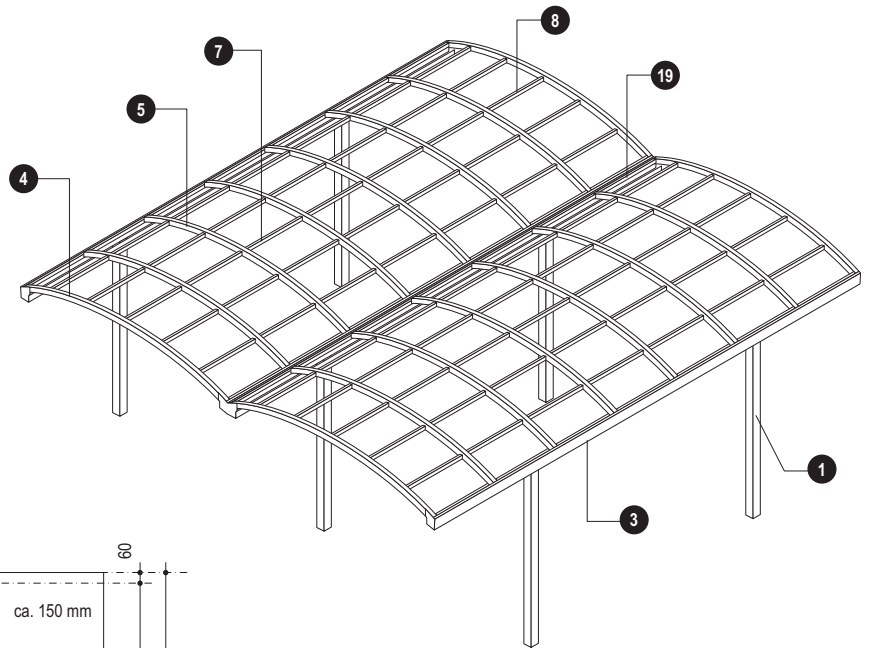

Maatvoering in verlengde gekoppeld

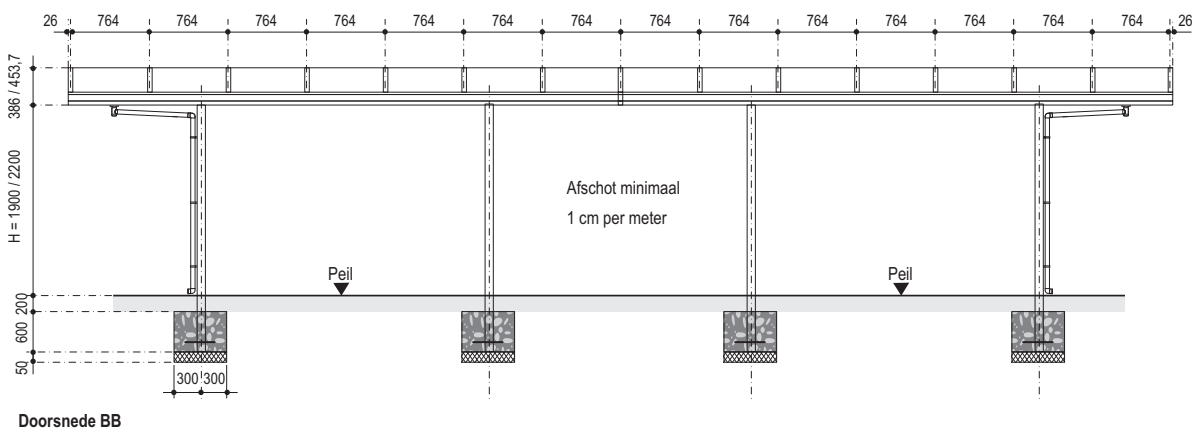
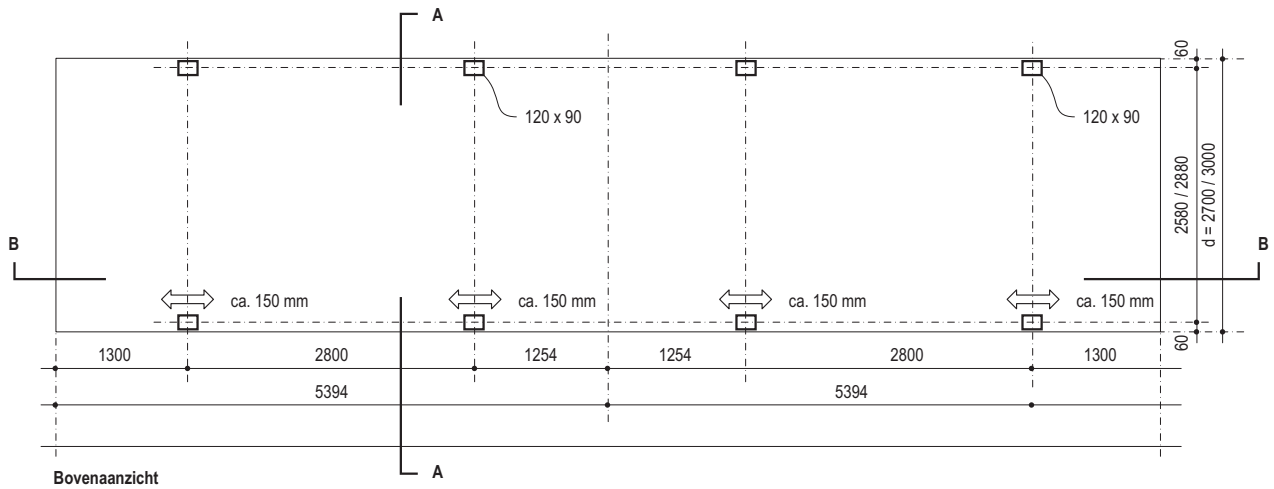
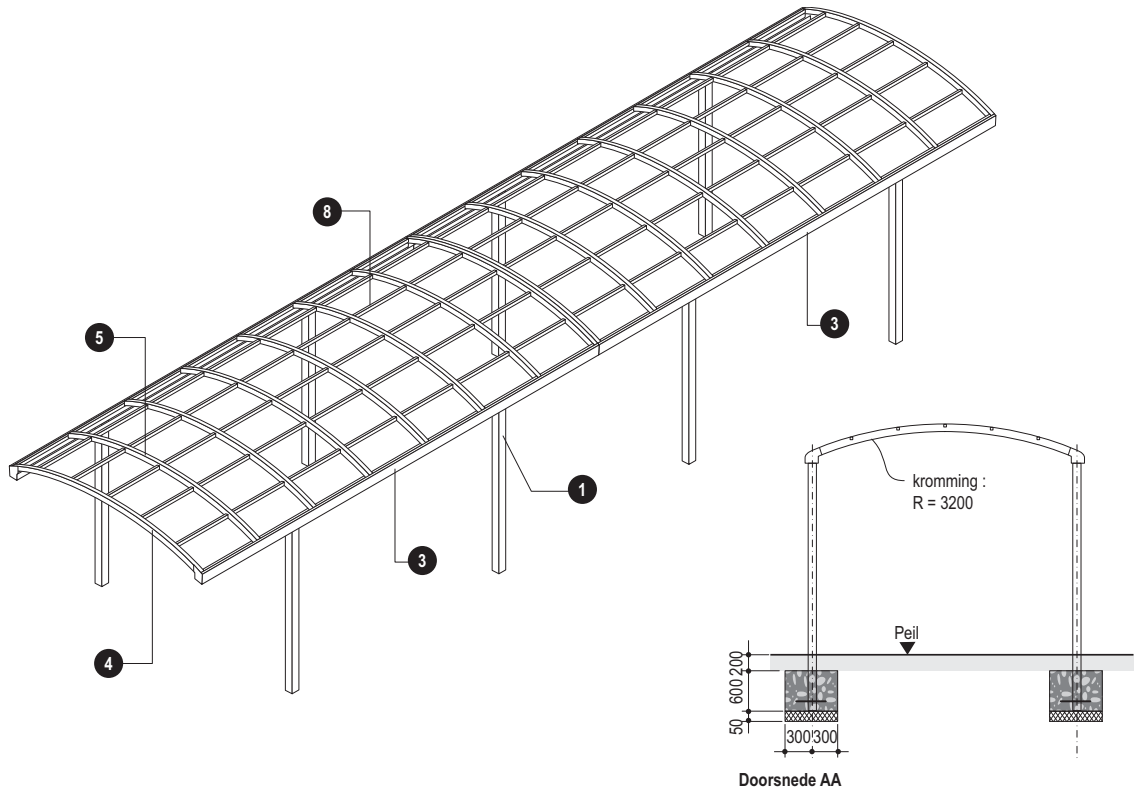

Voorzorgsmaatregelen

Let op!

- lees deze montagehandleiding eerst volledig door alvorens aan de montage te beginnen
- als u bepaalde onderdelen van de montage niet begrijpt, neem dan contact op met uw leverancier
- laat de montage van de carport uitvoeren door een terzake kundige monteur.

Waarschuwingen

- deze carport is voor gebruik onder normale omstandigheden
- als er een risico bestaat dat sneeuw van een dak op de carport kan schuiven, laat u dan een open ruimte tussen gebouw en carport.

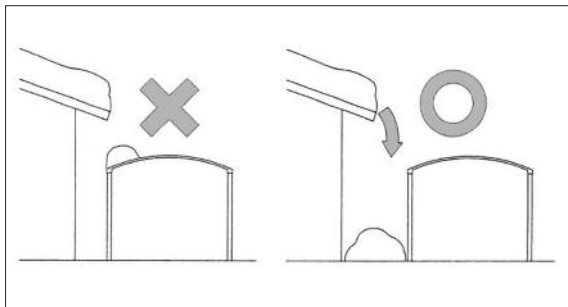

- zorg bij de installatie van de carport op een sterk aflopende oprit, dat de verankering van de laagste staander(s) voldoende is
- bepaal de positionering van de staanders zodanig dat deze niet in aanraking kunnen komen met de aanwezige gemeentelijke nutsvoorzieningen (gas-, water- en elektriciteitsleidingen)

Funderingen

- houd u aan de opgegeven maatvoering van de funderingen
- gebruik geen materialen die het aluminium van de constructiedelen kunnen eroderen
- de fundering dient op vaste grondslag te zijn; neem bij twijfel contact op met een constructeur
- de fundering dient vorstvrij te liggen; minimaal maai-veld minus 70 cm
- stort geen beton bij temperaturen lager dan 5 °C
- gebruik beton klasse C20/25 (voorheen B25), milieuklasse XC2. Let op! Voor de kustlijn geldt een andere milieuklasse
- maak onderin de poeren eerst een werkvloertje (stampbeton) van minimaal 5 cm dikte
- zorg er voor dat de staanders waterpas komen te staan en voldoende stabiel zijn afgeschoord gedurende de uithardingsperiode van het beton

- laat het beton na het instorten van de staanders voldoende uitharden alvorens het dakgedeelte te plaatsen; minimaal een uithardingsperiode van 4 dagen (7 dagen wordt geadviseerd)
- houd het beton bij extreme hitte nat gedurende de uithardingsperiode
- plaats geen (zware) voorwerpen op het beton gedurende de uithardingsperiode
- verwijder betonresten en cementsluier onmiddellijk van de aluminium delen om corrosie te voorkomen

Constructie

- monteer in volgorde zoals aangegeven in de montagehandleiding
- houd u exact aan de opgegeven maatvoering van de te maken boringen
- gebruik professionele apparatuur
- zorg voor een afschot van het dak van tenminste 1 cm per meter

Afwerking en controle

- als de staanders in een perk komen te staan, breng dan rondom de staanders bestrating aan, zodat regenwater kan afvloeien
- controleer na de montage of alle bouten en schroeven voldoende zijn aangedraaid en zo nodig geze-kerd.

Verbinding staander - gootligger (standaard)

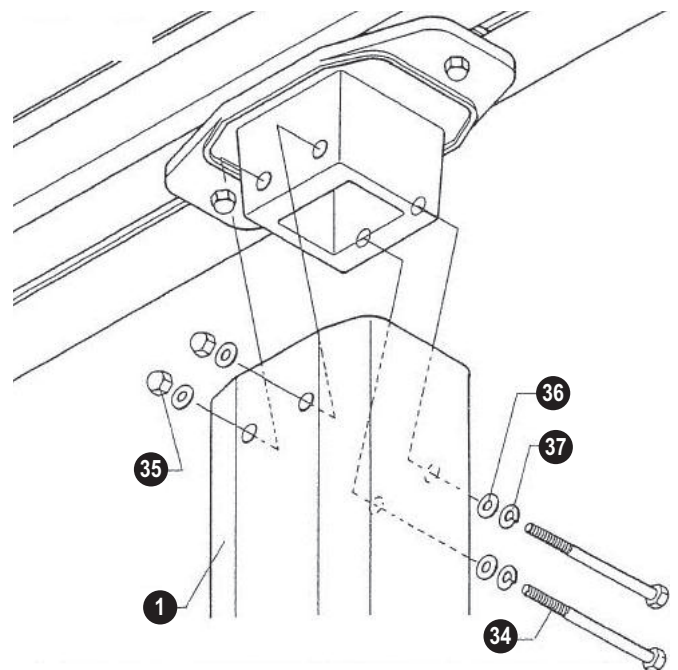
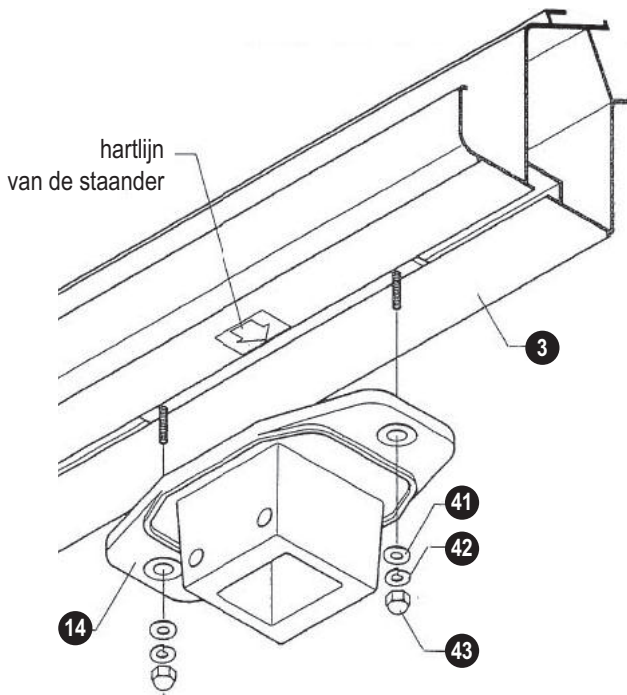
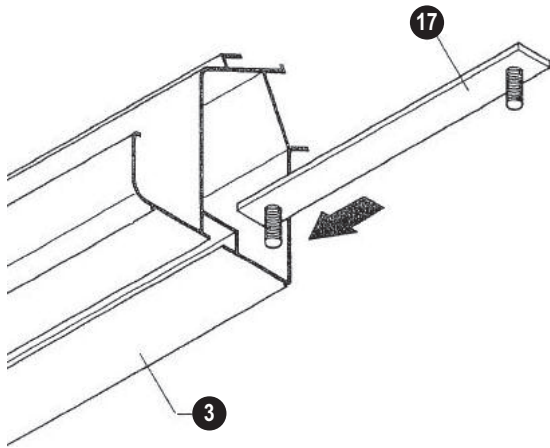
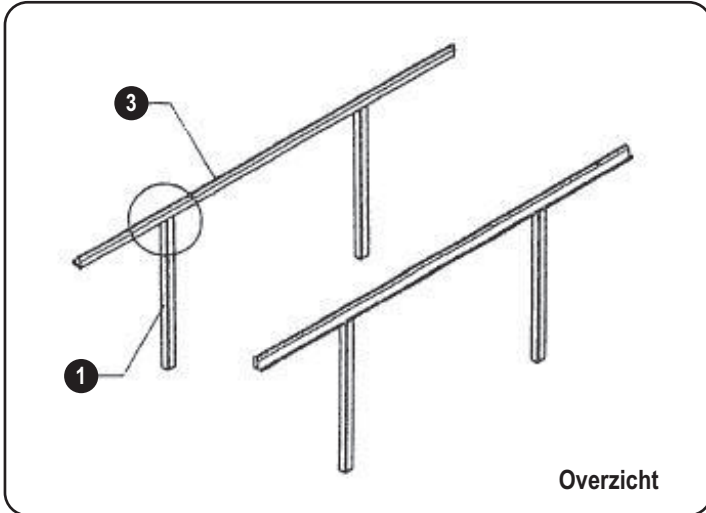

Verbinding staander - gootligger (in lengte gekoppeld)

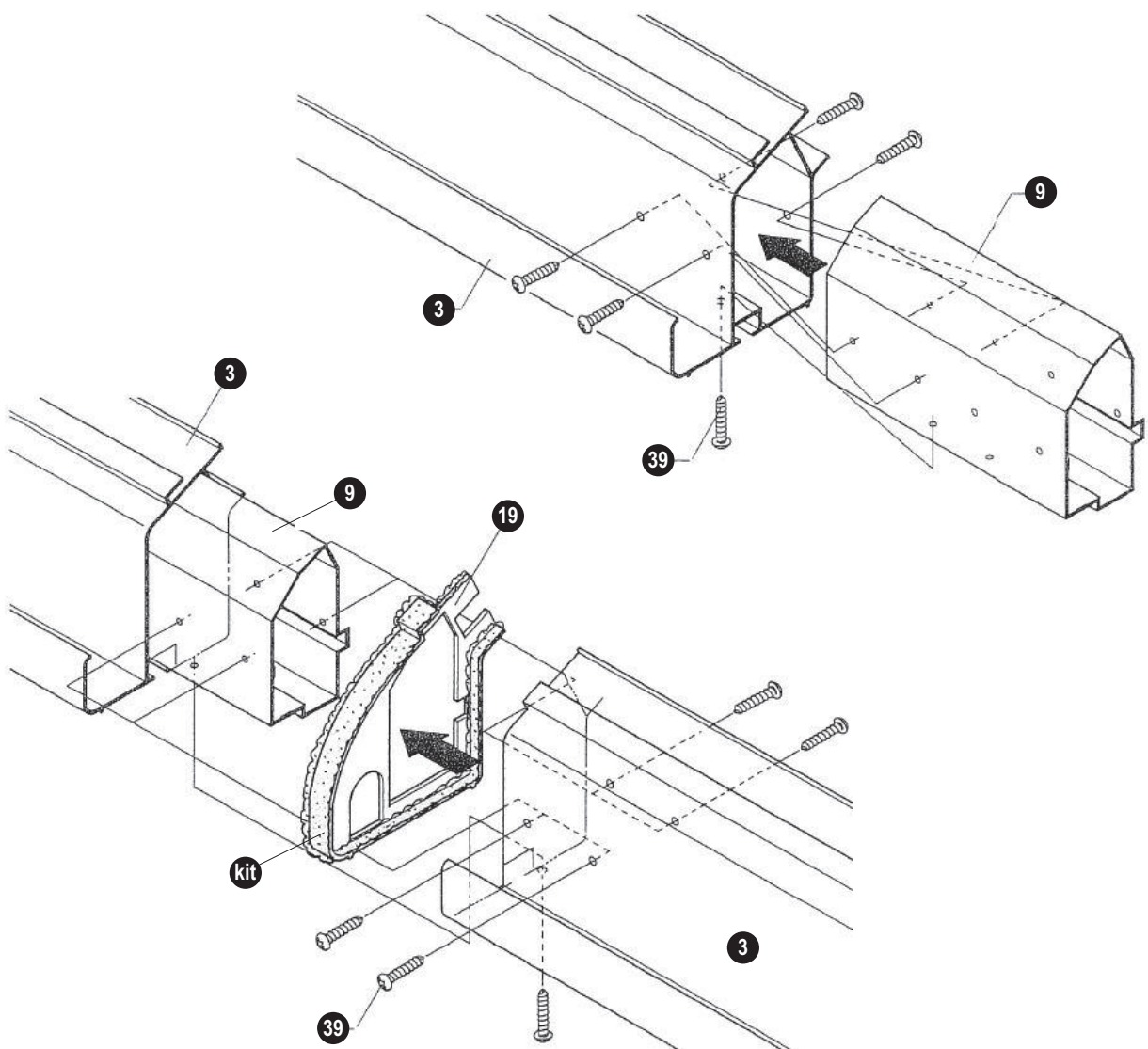
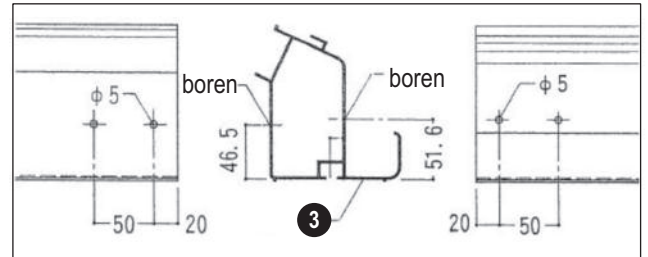
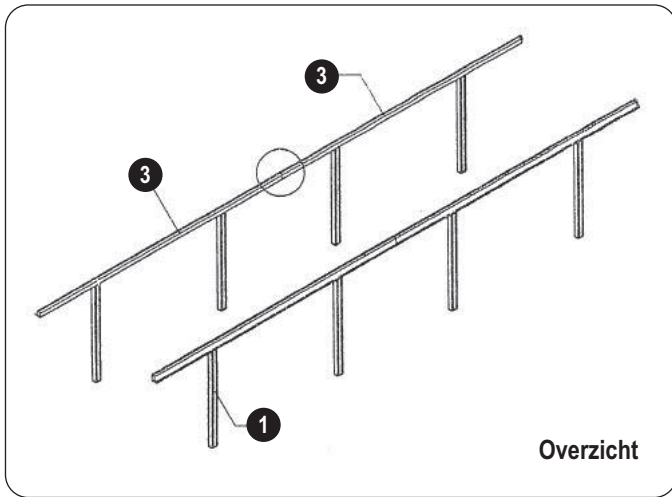

Verbinding staander - gootligger (zijdelings gekoppeld)

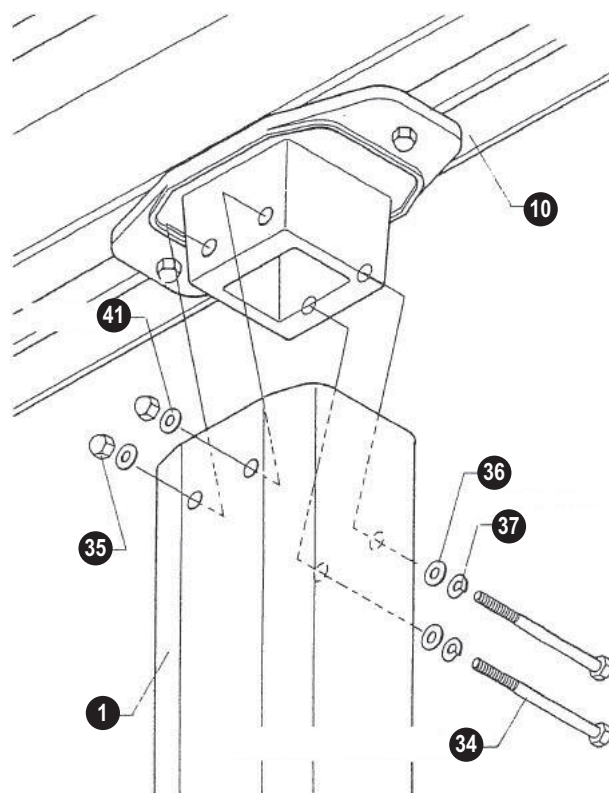
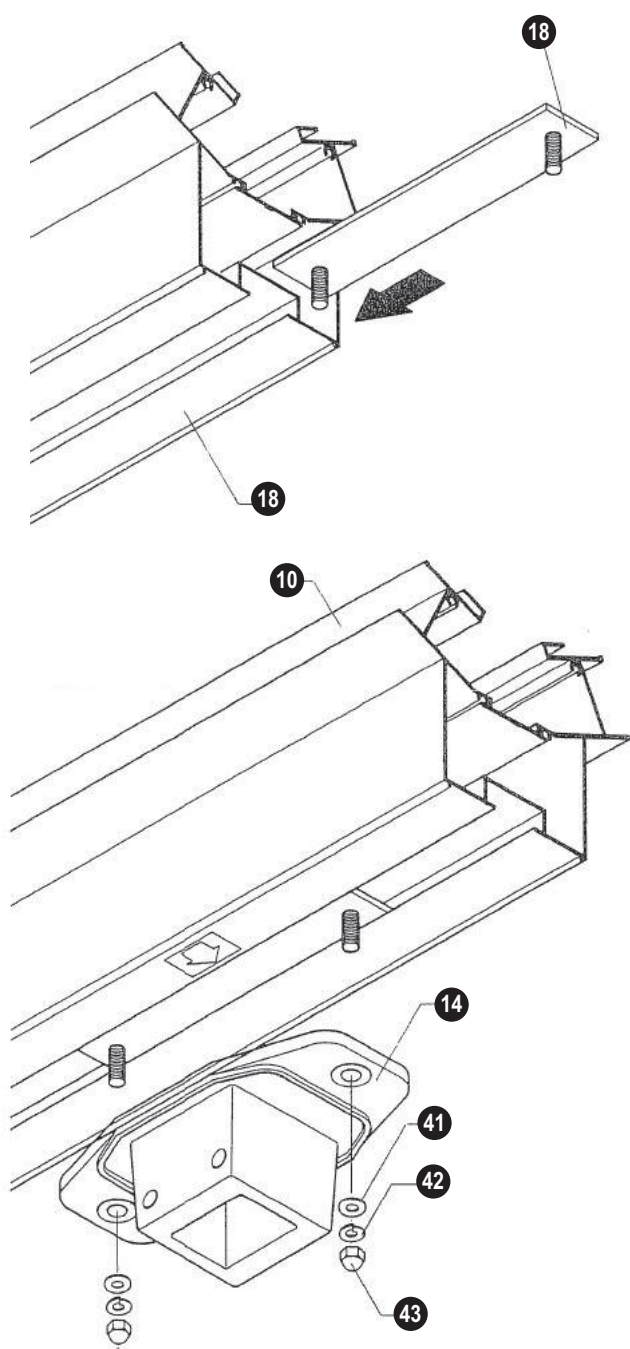
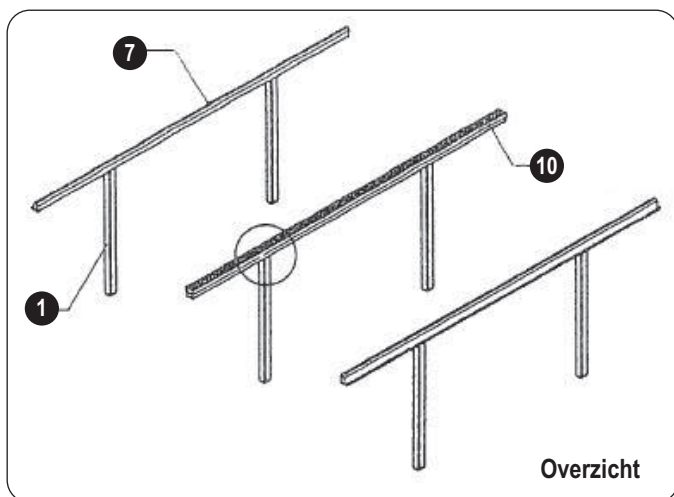

Bevestiging van de dakliggers

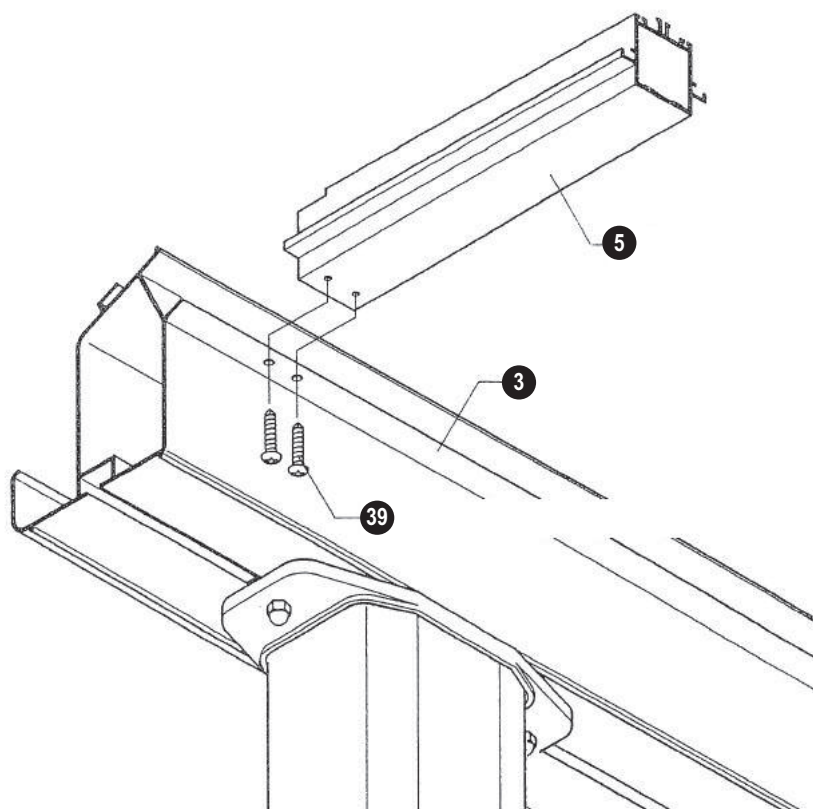
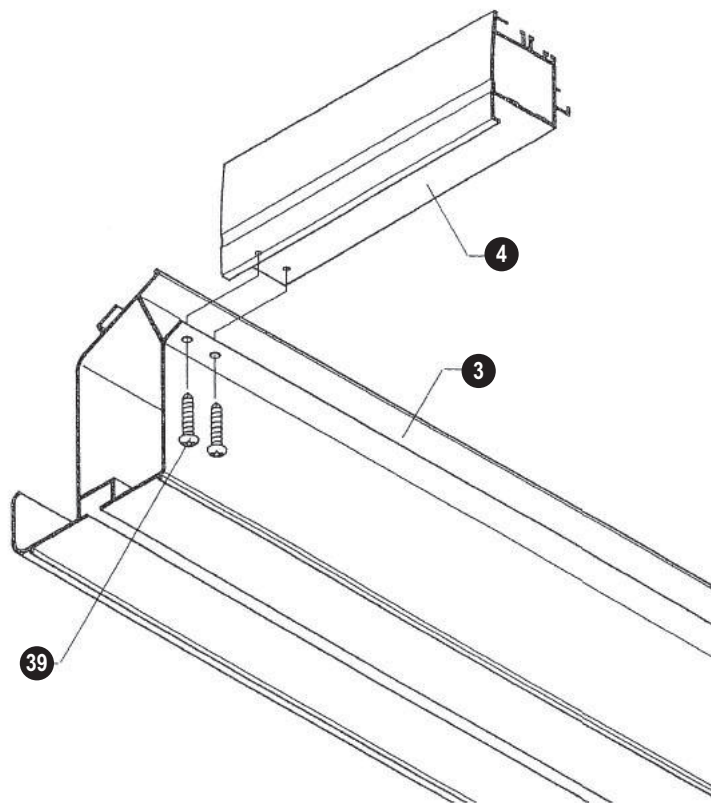
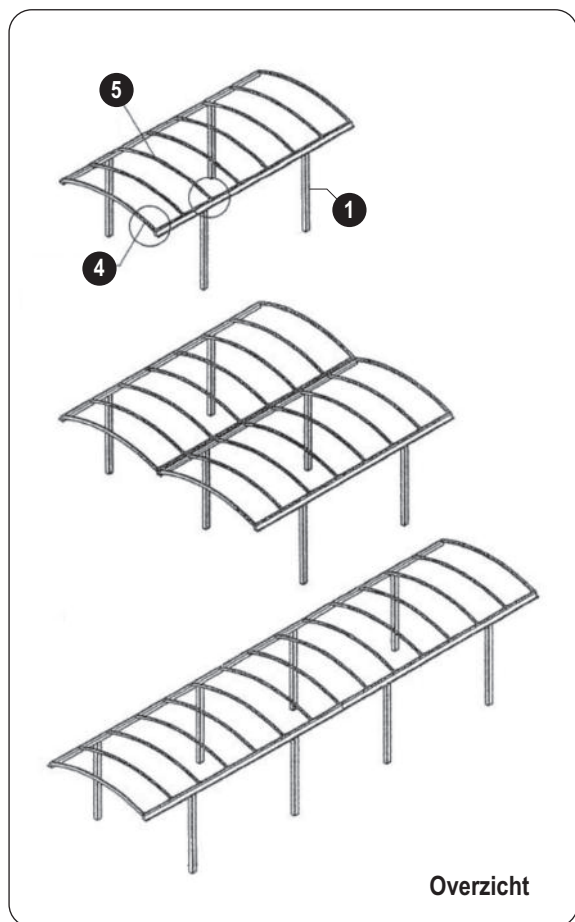

Aanbrengen van de beglazing

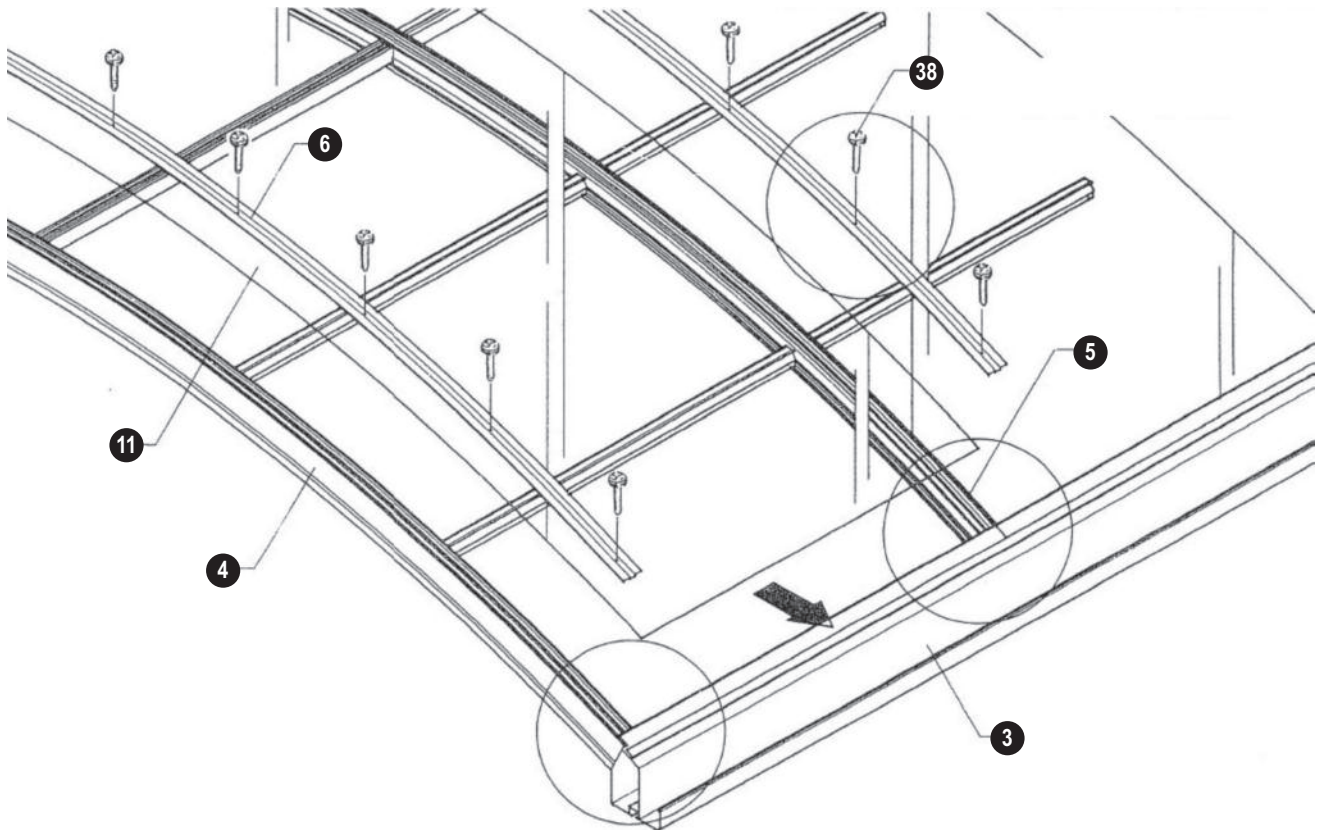
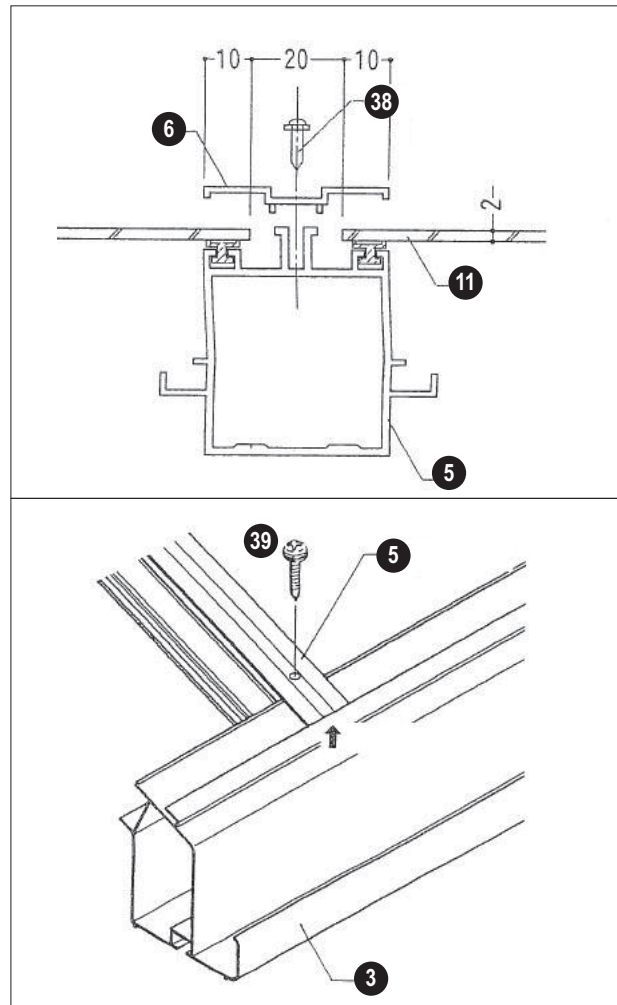
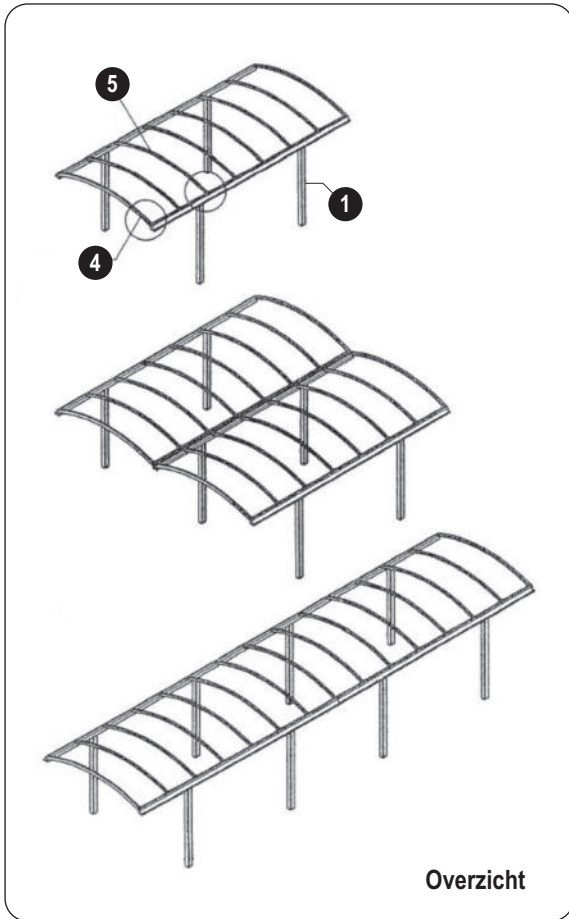

Montage van de hemelwaterafvoer (hwa)

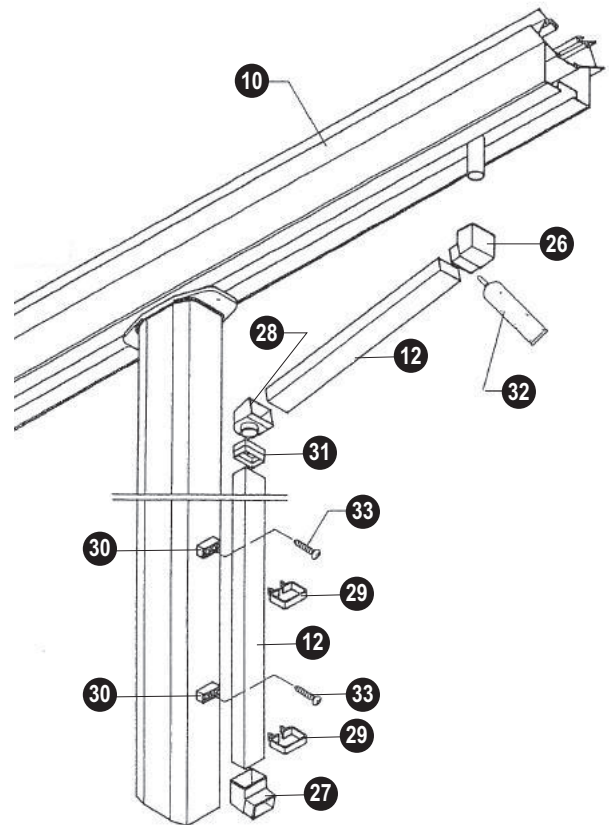
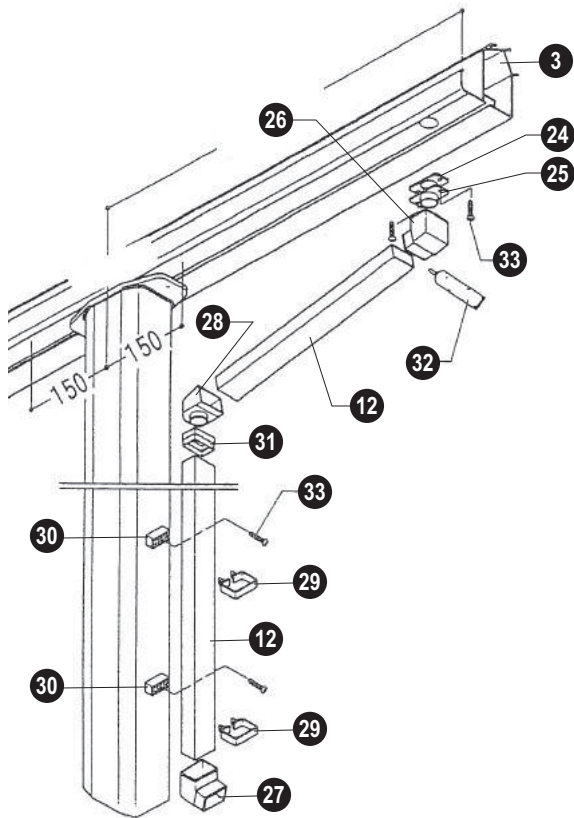
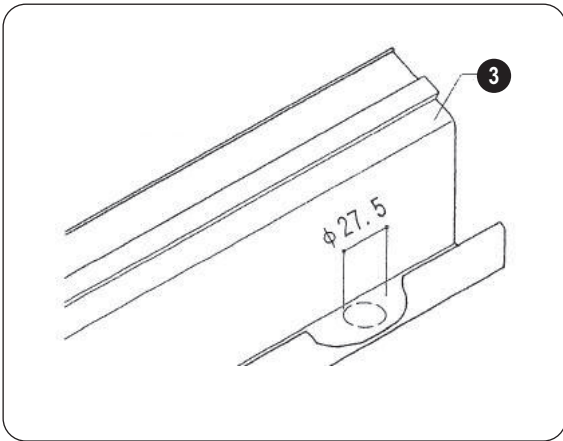

Montage van de eindkappen + kitten

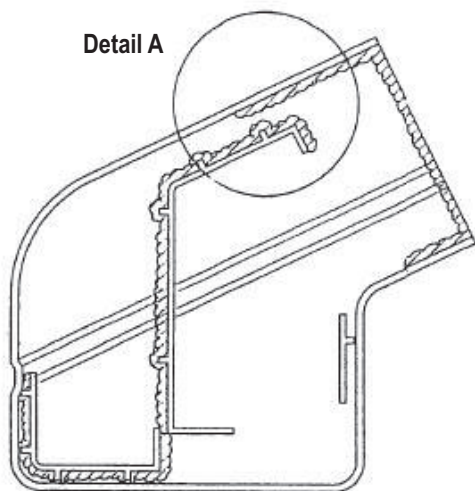

Detail A

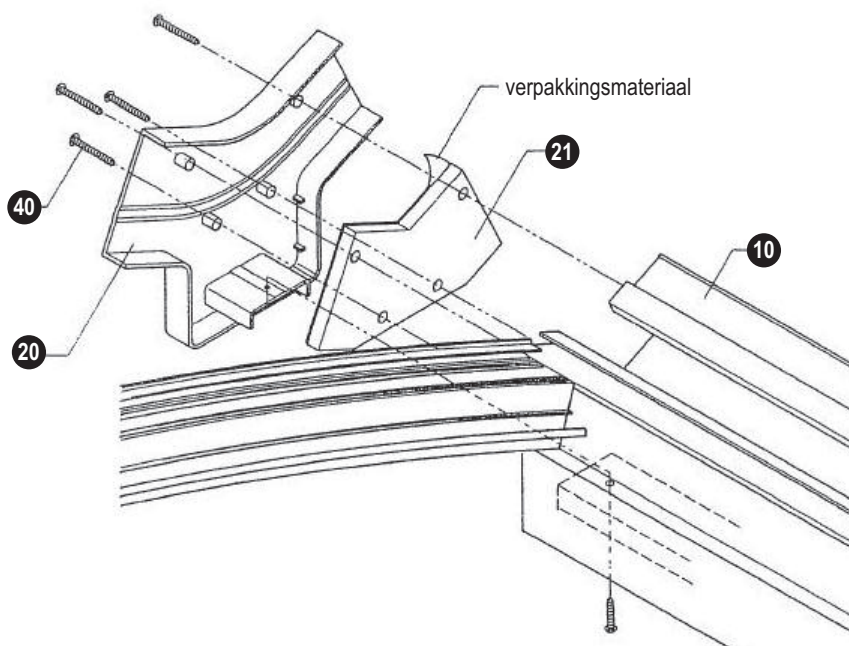
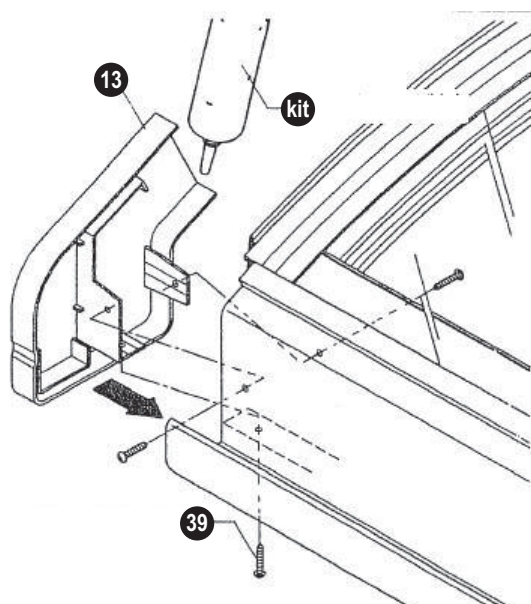
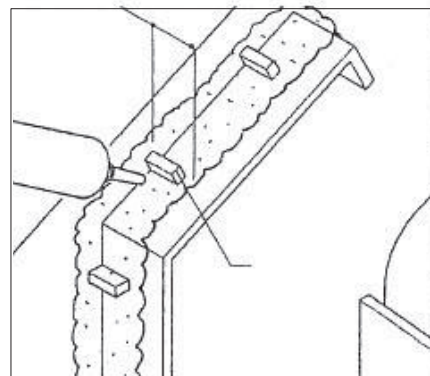

Novoferm, uw partner bij...

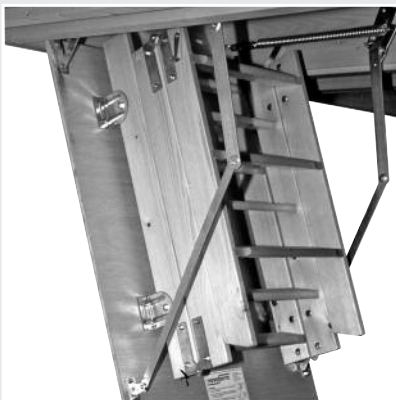

- Sectionaaldeuren
- Loopdeuren

- Kanteldeuren
- Vlieringstrappen

- Toegangsdeuren parkeerruimtes
- Carports

Novoferm Nederland BV
Bedrijvenpark Twente 187, 7602 KG Almelo
Postbus 220, 7600 AE Almelo
Telefoon: +31 (0)546 580 680 Fax: +31 (0)88 8888 580
E-mail: woningbouw@novoferm.nl Internet: www.novoferm.nl

novoferm[®]
Dé Carport!